

View from "A"

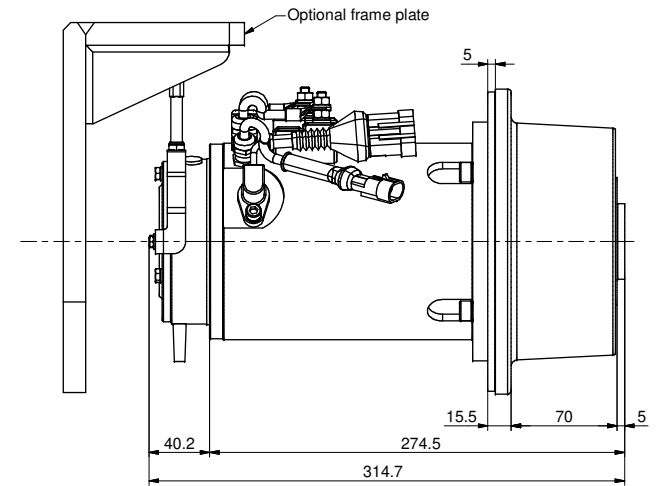

View with wheel and frame plate

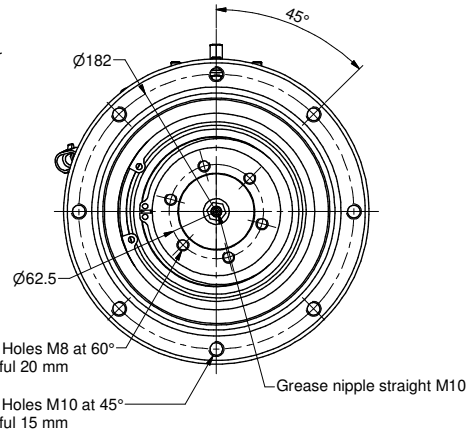
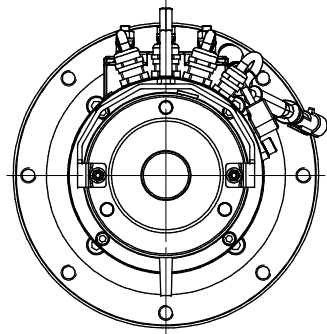
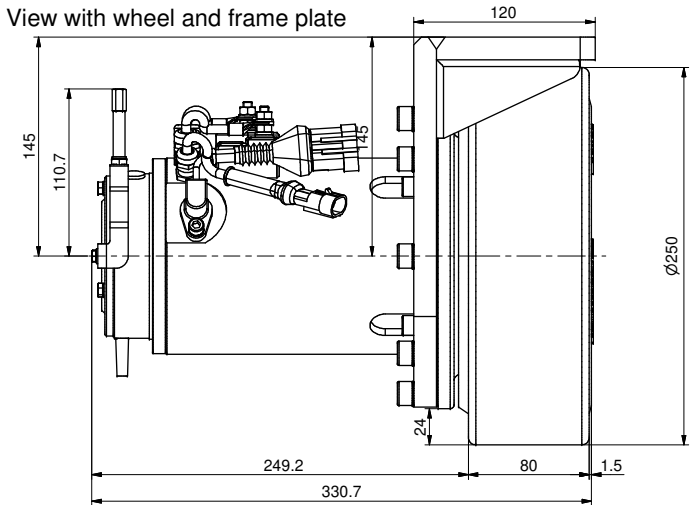

Thermal sensor KTY 84/130  
Plug AMP Automotive Superseal 1.5  
Series P2 282104-1

Radial sensor 48 PPR  
Plug AMP Automotive Superseal 1.5  
Series P4 282106-1

