

View from "A"

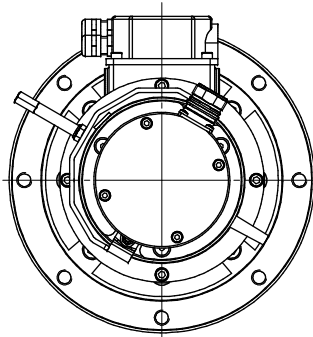

View with wheel and frame plate

