

Radial sensor 48 PPR
Plug AMP Automotive Superseal 1.5
Series P4 282106-1

Thermal sensor KTY 84/130
Plug AMP Automotive Superseal 1.5
Series P2 282104-1

Brake 40Nm

Thermal sensor KTY 84/130
Plug AMP Automotive Superseal 1.5
Series P2 282104-1

Radial sensor 64 PPR
Plug AMP Automotive Superseal 1.5
Series P4 282106-1

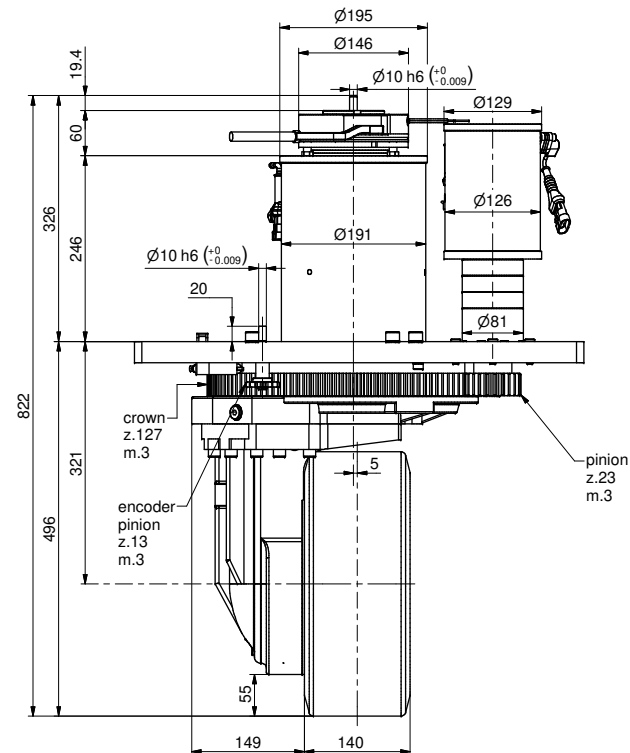
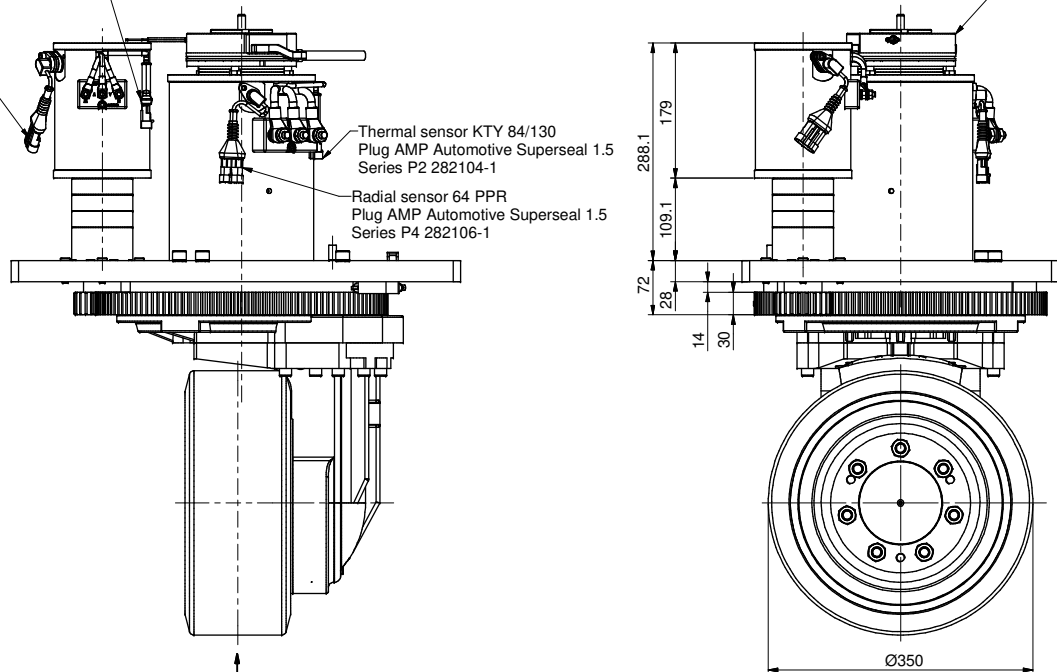

View from "A"

Microswitch XCMN2102L1
Angle 99°

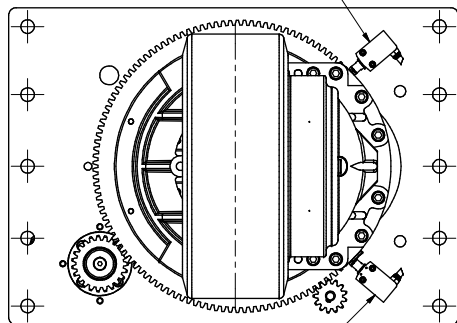

Microswitch XCMN2102L1
Angle 99°

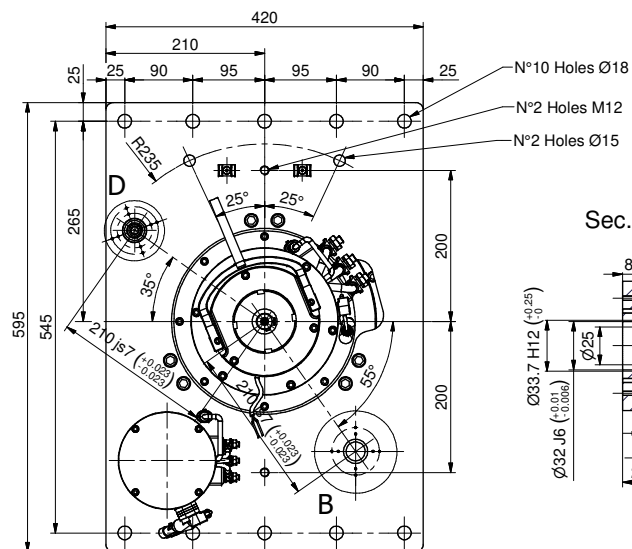

Sec. C-C

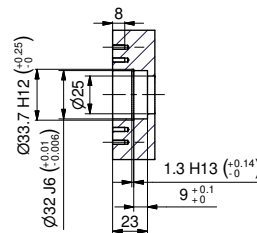

Detail B

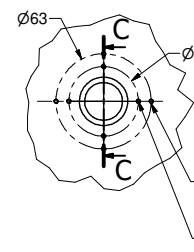

Detail D

