

View from "A"

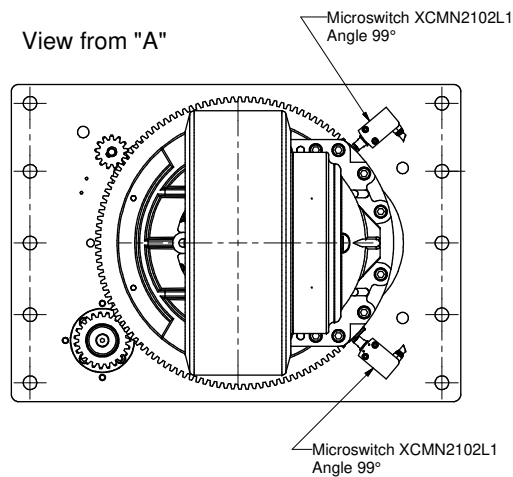

N°2 Holes M3 at 180°  
Useful 8

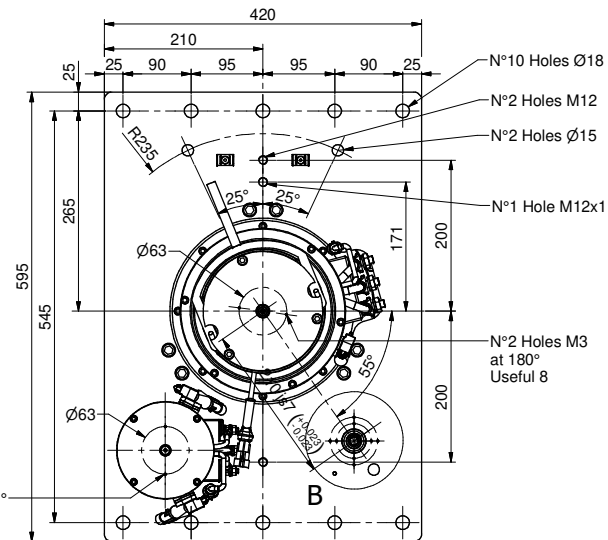

Detail B

