

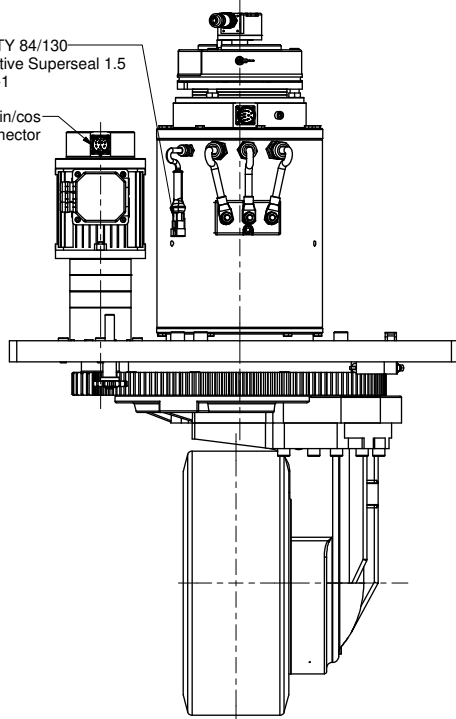

Thermal sensor KTY 84/130
Plug AMP Automotive Superseal 1.5
Series P2 282104-1

sin/cos
M23 connector



A

View from "A"

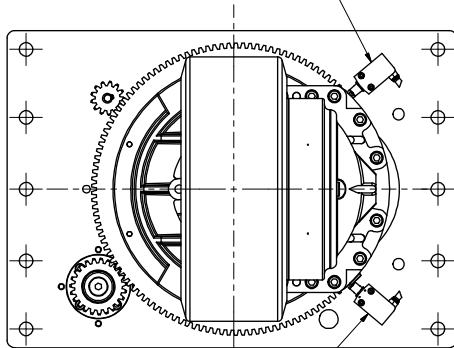

Microswitch XCMN2102L1
Angle 99°

Microswitch XCMN2102L1
Angle 99°

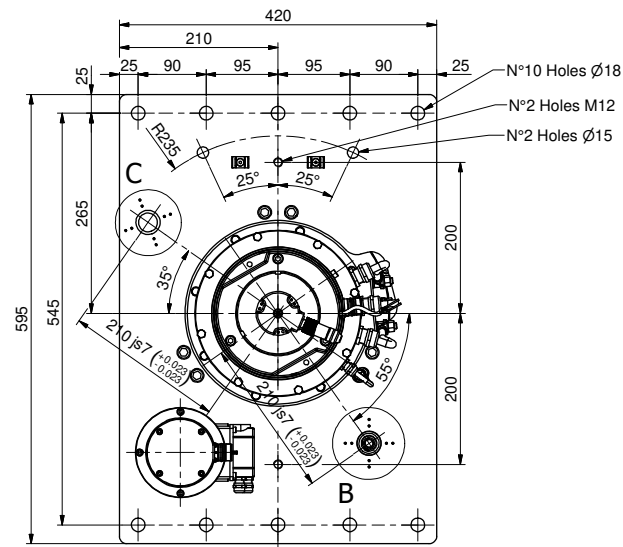
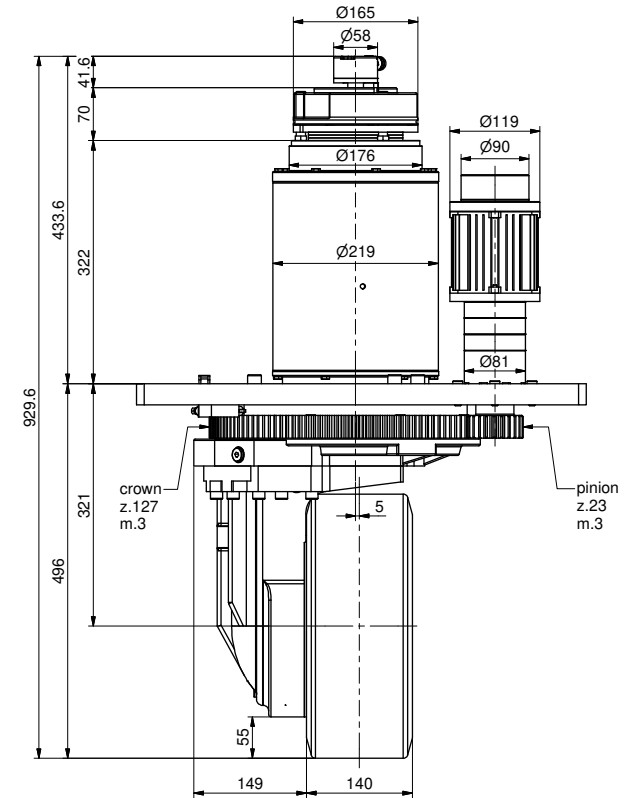
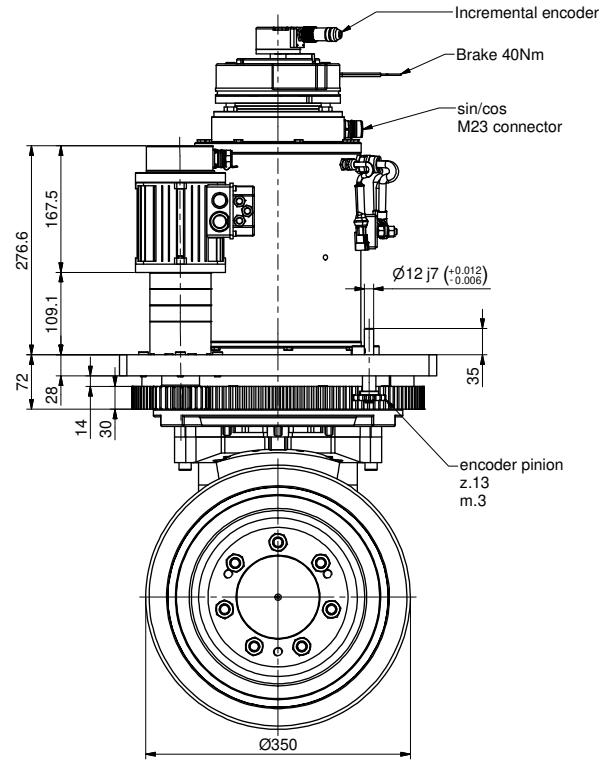

Detail B

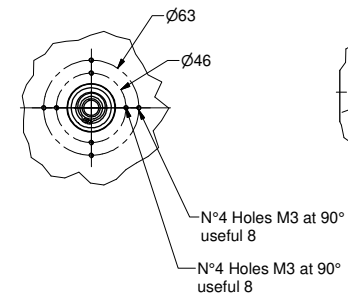

Detail C

