

View from "A"

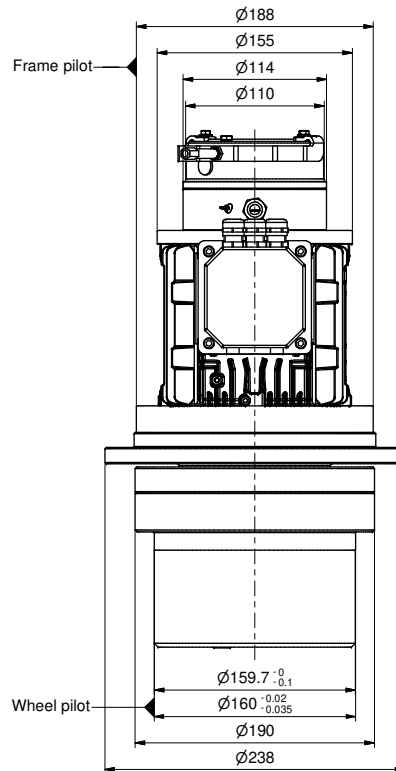
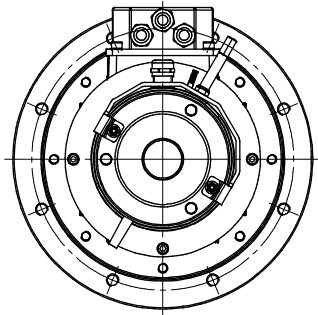

Bearing static load rating C1=C2= 190 kN

Bearing dynamic load rating C1=C2= 154 kN